

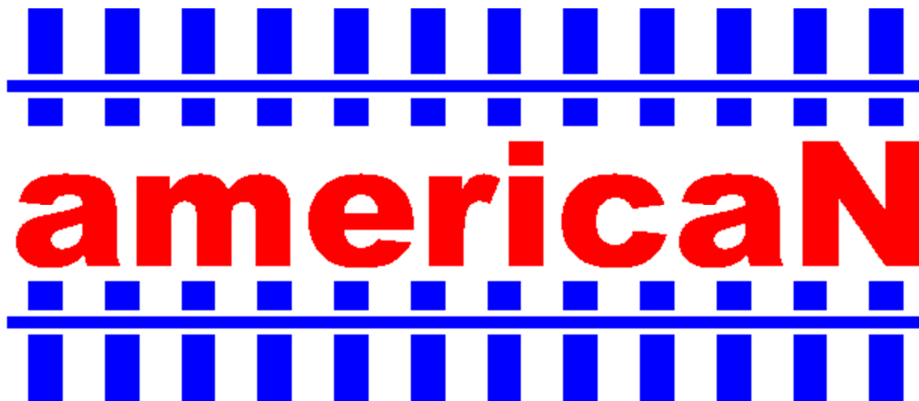

Standards for the FREMO modular system



Contents

1	Preface and Introduction	3
2	Notes on this version	3
3	Module structure	3
3.1	Geometry of module structure.....	3
3.2	End profile.....	4
3.3	Height of rail top	4
3.4	Module connection	4
3.5	Color of side panels.....	5
4	Track.....	5
4.1	Allowed track material	5
4.2	Minimum radius	5
4.3	Clearances and track axis distances	5
4.4	Uncoupling magnets.....	5
4.5	Throw mechanisms and controls.....	6
5	Rolling stock	6
5.1	Wheelsets	6
5.2	Couplers	6
5.3	Car weight	6
5.4	Motive power	6
5.5	Weathering	6
6	Landscape.....	6
6.1	Season, era and modeled region	6
6.2	Grass fiber / landscaping material	7
6.3	Color of track and ballast	7
6.4	Telephone poles.....	7
7	Electrical equipment.....	8
7.1	General remark.....	8
7.2	Electrical connection to track work.....	8
7.3	Electrical connection between modules	8
7.4	DCC booster.....	9
7.5	LocoNet.....	9
8	Color concept for car cards, waybills and staging yards.....	9
9	Car cards.....	11
10	Datasheet & waybills	11
10.1	General	11
10.2	Datasheet and car cards	11
10.3	Car card boxes at stations.....	13
11	Recommended materials	14
12	Links.....	14
13	Contact	15

1 Preface and Introduction

american is a module standard adopted by the FREMO (**F**riendscircle of **E**uropean **M**odelrailroaders). Modules build to this standard resemble single-track standard gauge railroad lines in North America in N-scale (1:160). There are no restrictions on either area or era.

This document contains standards as well as recommended practices for building and detailing **american** modules. There are also standards for materials necessary for prototype-oriented operations, for example car cards and waybills. Important aspects of the “Track Warrant Control” operations (which is our preferred method) are described in a separate short reference. This document can be loaded from the homepage of **american**.

The **american** module system was developed in 2001 because the initiators felt that the already existing module systems, NTRAK and oneTRAK no longer reflected the current philosophy of modular model railroading. In the **american** system the use of a prototypical traffic control system, as well as simulation of traffic flow with car cards and waybills, is very important. This overall concept already existed with FREMO module systems. For the **american** standard, many ideas were taken from FREMO H0(USA) and fremo-N. One other important aspect of **american** is the use of commercial track and turnouts.

The main characteristics of **american** are:

- free module geometry,
- height of rail top above ground 1300 mm,
- use of NMRA-DCC and LocoNet,
- prototype-oriented operations (Track Warrant Control)
- use of car cards and waybills.

2 Notes on this version

This version dated from 2011-10-01 replaces all previous versions of an **american**-standard. Modules built earlier can be used in the future, even if they do not meet all details of this standard. The changes are:

- Grass fiber / landscaping material (Chapter 6.2)
- Introduction of a new plug system (Chapter 7)

3 Module structure

3.1 Geometry of module structure

Length, width and angle of a module can be freely chosen, as long as the minimum radius of 1000mm on the main track is maintained. With respect to transportability, the length of a single segment should be kept below 1200 mm.

3.2 End profile

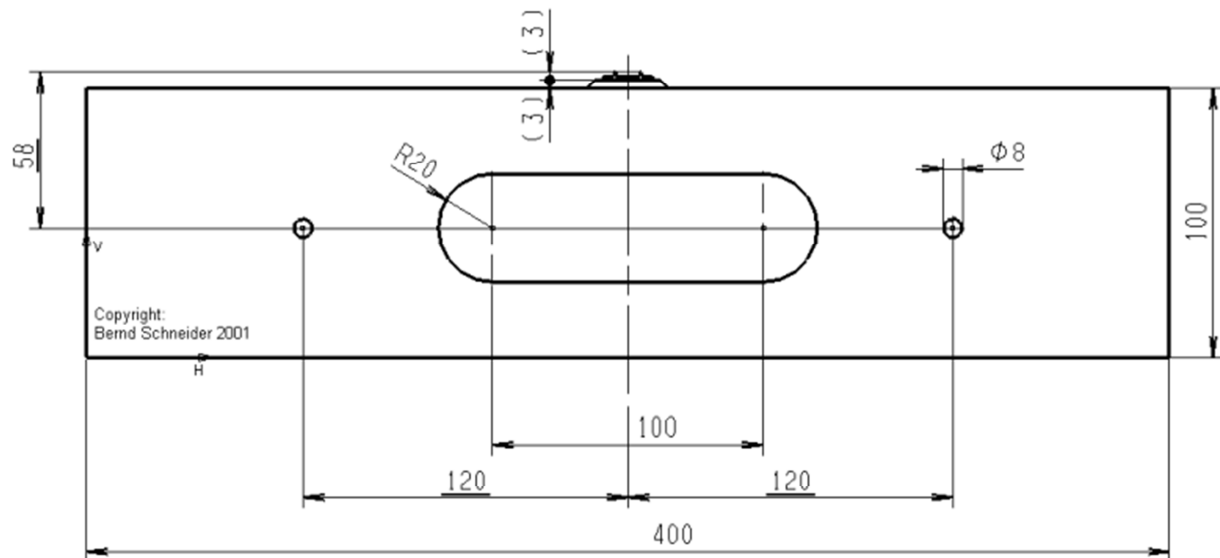

Image 1

The underlined items are identical to the dimensions of the FREMO end profile N90, so mechanical compatibility to other FREMO systems in N scale is maintained. The values in brackets refer to wide-spread, commercially available products.

NOTE: The 8-mm holes are NOT vertically centered! It is suggested to drill these holes only after track has been laid. A self-made cardboard template may be very useful.

3.3 Height of rail top

The rail top is at a height of 1300 mm above floor. The module legs must have the possibility to adjust height for +/-20 mm. Modules with a length of 500 mm and longer must be able to stand by themselves.

3.4 Module connection

The modules are mechanically connected with nuts, bolts (both M6 or 1/4") and appropriate washers. It must be possible to tighten the screws and nuts without tools, so its mandatory to use either wing screws, thumb screws or eye bolts and wing nuts. Rail joiners or connecting tracks are not used. The rails end flush or with a set back up to 0,2 mm at a RIGHT ANGLE to the end plate. For improved mechanical stability the rails must be soldered to PCB ties or brass screws at the end of the module. Tie stripes made of fiber-glass reinforced epoxy PCB are available from us. It is important to check the gauge after completion! The railheads are to be chamfered at the module ends (see image 2).

Rails must not run over the complete length of a module. For humidity compensation, a cut through both rails in the middle of the module is mandatory.



Image 2

3.5 Color of side panels

The side panels must be painted in a semi-gloss, beige color RAL 1001 Beige or equivalent.

4 Track

4.1 Allowed track material

The maximum allowed height of the visible rail is 1,4 mm, which is Code 55. At the moment there are two optically satisfying products resembling North American trackwork:

- Atlas Code 55
- Micro Engineering Code 55

Trackwork in yards and towns should be made of Atlas Code 55 flex track and #7 turnouts or greater. Atlas turnouts are “DCC-friendly” without modifications. The Micro Engineering Code 55 flex track has the advantage that MT wheelsets with high flanges can run on it without hopping.

Peco Streamline Code 55 track and turnouts can also be used. Turnouts must be modified that the frog has its own current supply and is not supplied through the points exclusively.

Custom-made trackwork is also acceptable if it conforms to NMRA standard S-3.2. For compatibility with MT wheelsets, flange clearance H must be at least 0.8 mm.

4.2 Minimum radius

Main track curves must be built with a minimum radius of 1000 mm.

4.3 Clearances and track axis distances

Clearances must be conform to NMRA standard S-7, and S-8 (using Class 1a rolling stock).

4.4 Uncoupling magnets

Uncoupling magnets are not allowed due to the possibility of unintended train separation. For Uncoupling, the *Rix Pick N scale uncoupling tool* or a similar device is used.

4.5 Throw mechanisms and controls

A location must be easily operable for crews unfamiliar with the “territory.” Thus, turnout controls (mechanical or electrical) should be close to the turnout. Switching locations in curves, as well as junctions, must be operable from both sides of the module. Mechanical systems are especially well suited for this.

Being able to operate from both sides of the module is very helpful in planning for successful arrangement of modules.

5 Rolling stock

5.1 Wheelsets

The wheelsets must be able to roll over Atlas Code 55 turnouts and flex track without touching the rail spikes.

5.2 Couplers

MicroTrains or compatible couplers which can easily be opened with the Rix Picks are mandatory. Kato or older Accumate couplers do not work properly!

As uncoupling magnets are not allowed, it is not necessary to adjust the trip pins. In unit train cars (passenger or freight) the couplers can be chosen freely. It is recommended practice to mount the couplers on the car body instead of on the trucks, as it provides smoother operation.

5.3 Car weight

Car weight must follow NMRA Recommended Practice RP-20.1: Initial weight 1/2 oz. + 0.15 oz./inch of car body length. This equals 14g initial weight plus 1.7g per cm car body length.

5.4 Motive power

As **american**N layouts are operated with NMRA-DCC, all motive power must be suited with an appropriate decoder. The speed curve must be adjusted in a way that maximum speed with cars on level track is approximately 60 mph (with reference to 14V track voltage, see 7.3). The half-way throttle position should be represented with about half of maximum speed. Acceleration and deceleration delay are to be switched off (CV3 and CV4), unless they can be toggled with FRED throttle control and are noted on the loco data sheet. If the decoder provides automatic change between analog and digital mode, that function must also be deactivated.

5.5 Weathering

Weathering is deemed a very important factor for giving a realistic flair on a model railroad. Therefore all rolling stock should show some weathering. Different grades of weathering are prototypical and thus welcome.

6 Landscape

6.1 Season, era and modeled region

The modeled season is summer. Neither a specific region nor era is specified, but if enough rolling stock is available for a specific era, meetings will take advantage.

6.2 Grass fiber / landscaping material

The best results in landscape modeling can be achieved by using a mixture of conventional turf and electrostatic grass. For the area at the module ends a blend of the following Woodland Scenic turfs should be used:

- for arid zones: two parts T50 earth blend, two parts T43 yellow grass, one part T44 burnt grass;
- for humid zones: two parts T44 burnt grass, one part T45 green grass, two parts T50 earth blend.

For modelling prairie landscape we recommend a basic mixture of one part Heki Sommerwiese (3360), one part Heki Wildgras (3367) and one part Heki Winterboden (3363).

6.3 Color of track and ballast

The main line (rail and ties) must be of dark grey color (we recommend Tamiya XF-63 German Grey). Ballast must be of middle grey color (we recommend ASOA Diabas N scale nr. 1409).

All other track work should resemble track maintained to a lesser degree than the main line. Rail and ties should be colored in brown. Colors called “rust” are normally way too red and therefore are not to be used!

6.4 Telephone poles

Poles are a simple way for giving some 3D appearance to rather flat modules. Thus, pole lines are to be installed (we recommend Atlas #2801). The poles must be painted grey, the insulators white or green. If the module has a distinct “viewing side,” the poles should be located behind the track. The number of poles n is calculated as follows: $n = \text{length-of-module} / 25 \text{ cm}$ (round to closest number). The distance a from the module end to the first pole therefore is $a = \text{length-of-module} / (2n)$. Distance between poles is $2a$.

7 Electrical equipment

7.1 General remark

Any electrical connections between modules and segments must be made with the imperative of non-compatibility between power receptacles and the plugs on the the SELV (Safety Extra Low Voltage) – side. This means, that on the SELV side no plugs are allowed on modular arrangements which can be plugged in power receptacles. Furthermore any 230 V (120V) wiring within the modules is strictly forbidden.

The chosen plug / socket type must be designed to handle the typical current for modelrailroads. Thus it is recommended to use stackable 4mm plugs with rigid insulating sleeve and the appropriate sockets also between segments.

In Chapter 11 we listed manufacturers and sources of supply. In the picture below you see the stackable 4mm plugs with rigid insulating sleeve SLS425-SE and the socket SLS405-BK made by Multi-Contact.

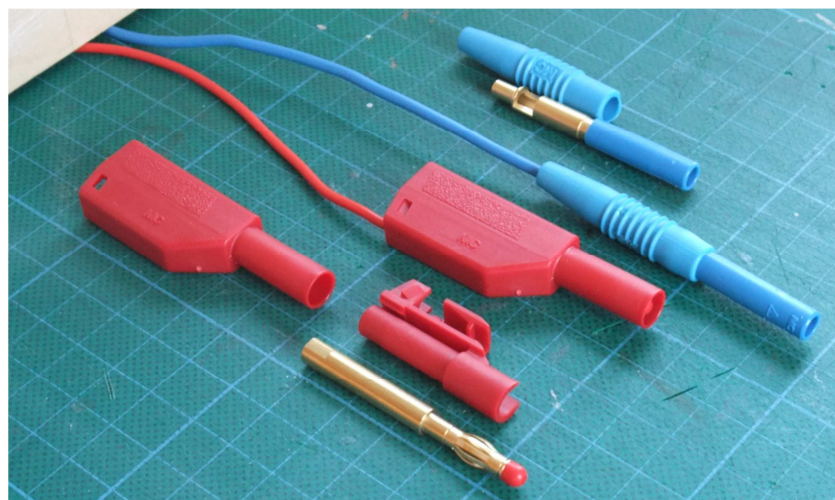

7.2 Electrical connection to track work

Because of the high specific resistance of rail, the track current must primarily pass through a feeder line, or track bus, parallel to the tracks and be fed into the rail in more than one location. The cross section of the track bus must be at least 0.75 mm^2 or 18 AWG in order to minimize voltage drop. The short, feeder connections from the track bus to the rails can be made with reasonably thin wire. Each rail profile piece must have its own connection to the track bus, as rail joiners tend to oxidize with time.

7.3 Electrical connection between modules

As there are no rail joiners between modules, current must be passed from module to module using cables. The connection is made with stackable 4mm plugs with rigid insulating sleeve and the appropriate sockets. The right rail (in running direction toward the end of the module) must use a plug connector, the left-hand rail a socket. This ensures correct connection. The cables should stick out for about 20 cm from the modules end in order to ensure easy connecting.

7.4 DCC booster

Bigger yards and stations must have their own LocoNet-compatible booster. Track voltage must be set between 13 and 15 Volts. Both cables from the booster to the track bus must have stackable 4 mm plugs with rigid insulating sleeve.

7.5 LocoNet

The LocoNet network is separately made from LocoNet boxes and compliant cables, so there is no need to provide LocoNet connections in the modules.

8 Color concept for car cards, waybills and staging yards

Waybills for ladings running to a staging yard and all car cards must have a color code. At gatherings the staging yards are also color coded.

Our color concept is based on the *home districts* for freight cars, which were in use until about 1970. Image 3 on the next page shows the *home districts* for the United States and Canada with their respective road names. Image 4 shows an aggregation of these districts and Mexico into seven color areas.

Waybills for ladings running to a staging yard get a color code at top left (see image 5).

Cars in use up to about 1970 get a code according to their home districts. Newer Cars get a maximum of four colors according to the network of the railroad. For example an older UP car gets the color codes Green, Yellow and Orange (see image 5). An actual KCS car could get Yellow, Orange, Grey and Black.

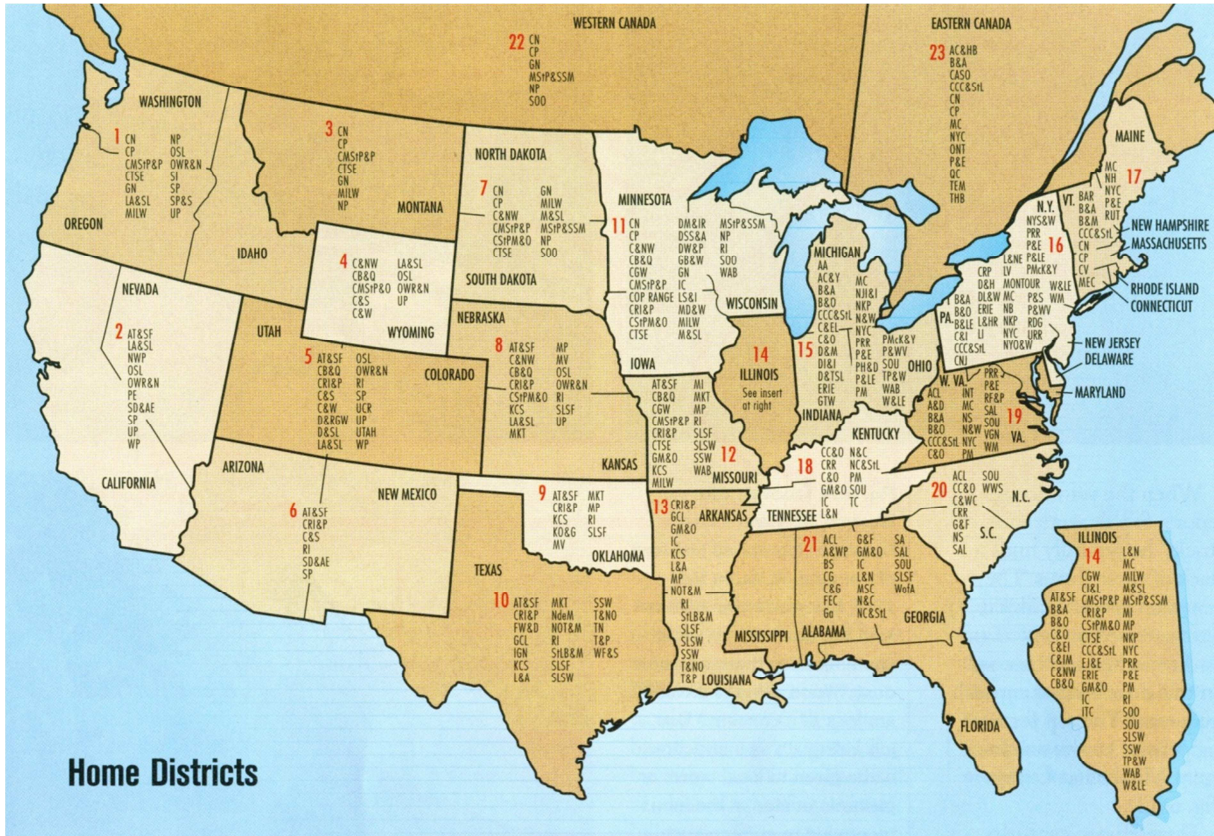

Graphic reproduced with friendly permission of © Kalmbach Publishing Co.
Image 3: Home Districts

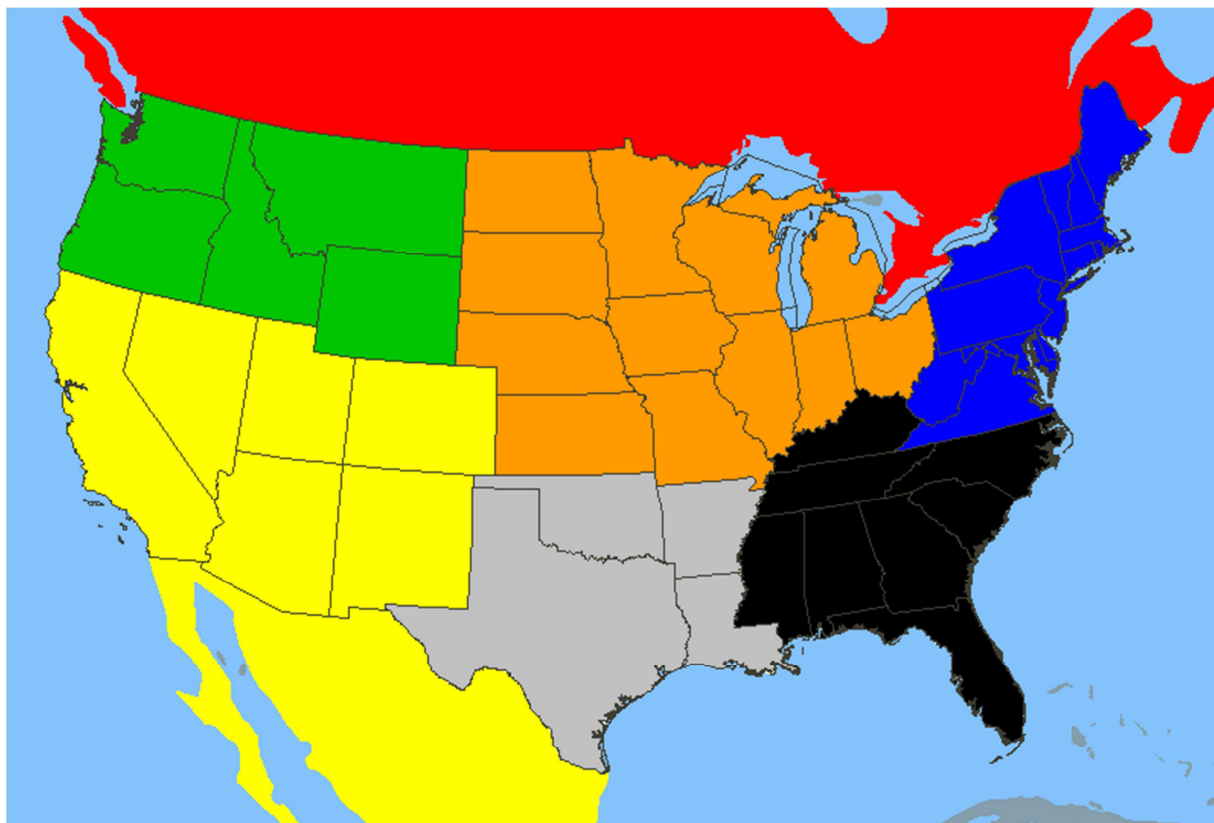

Image 4: Color areas for markings on car cards and waybills

9 Car cards

Every freight car used in an operating session must have its own car card, providing the following information:

- name of railroad
- car number
- car type
- AAR type
- a color code according to chapter 8

For color coding self adhesive points from Herma or Avery Zweckform can be used. For easy identification it would be nice to have a picture of the car on the front of the card.

Groups of cars which travel as units and are not separated during a session can have a single card for the whole group (coal or cement unit trains, for example).

Dimension of car cards: height 100 to 105 mm, width 54 to 60 mm and pocket depth 38 to 40 mm.

It is recommended to print the car card on index board, for example Brunnen Karteikarten unliniert, Art.-Nr. 10-22 400 10. Templates in MS Excel format are available on the **american**N homepage.

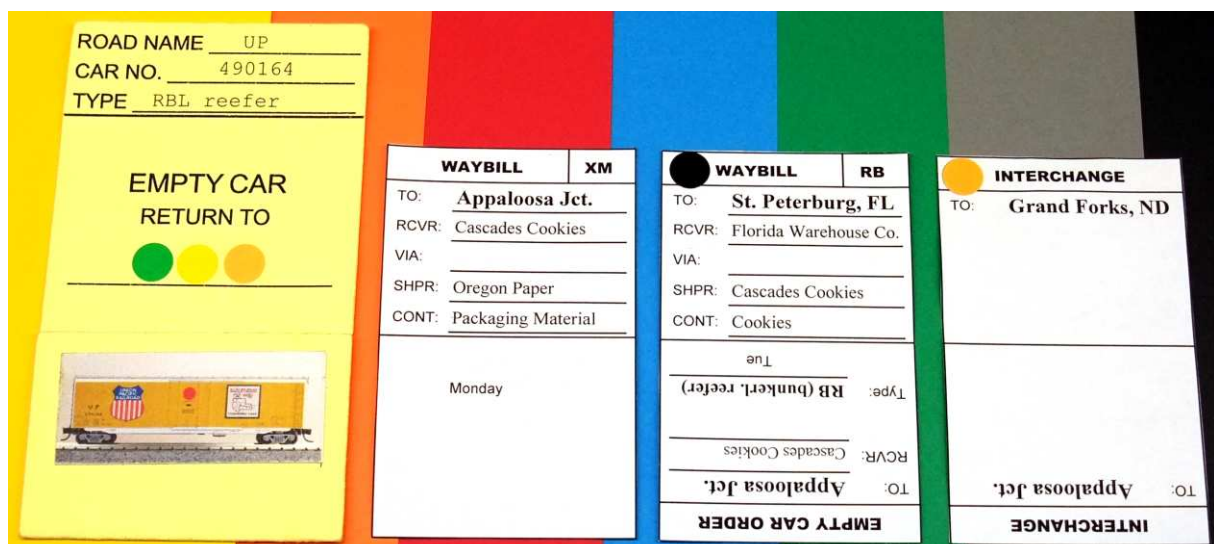

Image 6: car card and waybills

10 Datasheet & waybills

10.1 General

Each location that generates or receives freight must have a datasheet. This must be provided at meetings. Additionally, the owner of the location must provide the necessary waybills. These waybills don't have to be made for each meeting, but can be used again.

10.2 Datasheet and car cards

Our datasheet is based on a *Bahnhofsdatenblatt* that was introduced in the FREMO-Hp1-magazine 2/2004 by Knut Habicht and Bernd Schmedes. The major difference is the listing of all in- and outbound freights for all spots per operation day. Design and content should be illustrated on the basis of the extract of the data sheet for Appaloosa Junction in image 6.

On top left is a schematic track plan with named tracks. To the right is the approximate length of the sidings. The most important part is the chart. The "Track" column is the same identifier

as in the track plan. If a track has more than one spot, these spots are listed separately in the column “Spot.” According to the available track length, there is one row for one car length at a specific spot. For example the team track has four rows because of its length for four cars. The ramp at the team track is mentioned in a separate row.

The freights are treated similarly, one row for every type of freight. If there are more different types of freights than track capacity, the track capacity is mentioned additionally in the column “Spot.” For example, the ramp at *Cascades Cookies* has only a capacity of two cars but four different types of loads.

In the “In” row, the inbound goods are listed; in the “AAR type” row, the necessary car type; and in the “Out” row, the outbound goods are described.

The following seven double rows are the weekdays. Here the owner registers at which weekday what good has to be delivered or collected to or from what spot.

On the basis of the datasheet, the owner of the location makes his set of waybills. Waybills or empty car orders must show the weekday. (See MS Excel Sheet on the **americanN** homepage).

With the datasheet and the waybills it is now quite easy to build up the trains in the staging yards. The owner of the location gives the waybills of each day and the datasheet to the “yard master”. Now the “yard master” just has to look for a car with its car card and inserts the waybill or empty car order in the car-card’s pocket.

Appaloosa Junction, WA (AJ)

Track	Spot (capacity)	in	AAR Type	out	Mo	Tu	We	Th	Fr	
Farmers Coop	Door1	MTY	RP, RPL	fruits & vegetables	out	in	out	in	out	in
	Door2	MTY	RP, RPL	fruits & vegetables	out	in	out	in	out	in
Team Track			all							
			all							
			all							
			all							
	Ramp									
Cascades Cookies	Ramp (2 cars)	Packaging material	XM	MTY		in	out			
		Bakery supplies	RB	MTY	out	in	out	in	out	in
		Edible fat	RP	MTY			in	out		in
Sugar shed	Sugar	LQ	MTY				in	out		
Barrows Fuel & Oil	Coal dock	Coal	HM	MTY		in	out		in	out
	Unloading pipes (1 car)	Gas	TA	MTY			in	out		
		Diesel	TA	MTY						in
	Shed	Oil Drums	XM	MTY				in	out	
Interchange track			all		out	in	out	in	out	in
			all		out	in	out	in	out	in
			all		out	in	out	in	out	in
			all		out	in	out	in	out	in

() - 5 cars per day with correspond

Image 6: Datasheet

The “in” and “out” columns for the team track and the interchange track are intentionally not filled out. To have a possibility to vary the operation sessions in some degree, it is the location owner’s task to add some waybills for these spots to the other waybills for a weekday. So waybills must also exist for these two spots, but without a marking for a specific weekday.

We use three types of waybills:

- waybill for inbound freight (one-cycle)
- combined empty car order / waybill (two-cycle)
- interchange waybill (two-cycle)

The first two are normal waybills for loadings to local customers. On the combined bill the waybill side gets a color coding according to chapter 8. On the interchange waybill the side with the run back direction is color coded for the freight destination.

10.3 Car card boxes at stations

Every station or site must have a box for car cards. The pocket should be 65 mm wide. Every customer should have its own compartment with an appropriate labelling. Stations should also have an “off spot” compartment for cars that could not be spotted and an “outbound” compartment for cars that were already switched from their loading/unloading spot.

11 Recommended materials

Electrical connectors: Conrad electronics has appropriate articles.

Stackable plug from Hirschmann: 735026 – 62

Socket from Multi-Contact: 730956 - 62

Please contact us. We perhaps can offer the connectors from Multi Contact shown in the standard at preferable conditions.

PCB ties stripes: Stripes matching to Atlas Code 55 – tracks can be purchased from us. Also look at www.fremo-net.eu/index.php?id=922

Here a short overview over the material recommendations in this standard. Walthers-Numbers are marked with this symbol: #.

Asoa	Diabas ballast N	1409 (200ml)
Atlas	Telephone Poles	# 150-2801
Rix	N Scale Uncoupling Tool	# 628-24
Tamiya	XF-63 -- German Grey	XF-63
Heki	summer grass	3360
Heki	wild grass	3367
Heki	winter soil	3363
Woodland Scenics	T43 - Fine Turf -- Yellow Grass	# 785-43
Woodland Scenics	T44 - Fine Turf -- Burnt Grass	# 785-44
Woodland Scenics	T45 - Fine Turf -- Green Grass	# 785-45
Woodland Scenics	T50 - Blended Turf -- earth	# 785-50

12 Links

ASOA	www.asoa.de
Atlas	www.atlasrr.com
Avery Zweckform	www.avery-zweckform.com
Conrad electronic	www.conrad.com
FREMO (Freundeskreis europäischer Modellbahner)	www.fremo-net.eu
Herma	www.herma.de
Kalmbach Publishing Co.	www.kalmbach.com
NMRA (National Model Railroad Association)	www.nmra.org
Multi-Contact AG	www.multi-contact.de
Rix	www.rixproducts.com
Tamiya	www.dickietamiya.com
Walthers	www.walthers.com
Woodland Scenics	www.woodlandscenics.com

13 Contact

Bernd Schneider
Weikersheimer Straße 24
70435 Stuttgart
Germany

Tel: +49 (0) 151 10 72 31 89
homepage: www.america-n.de
email: kontakt2011@america-n.de